

# JMCG Facts

The only commercial vehicle company establishing joint-ventures with 3 of Fortune Global 500 enterprises in China ( Ford, Isuzu, Renault )  
Over 5 decades of experience in manufacturing vehicles

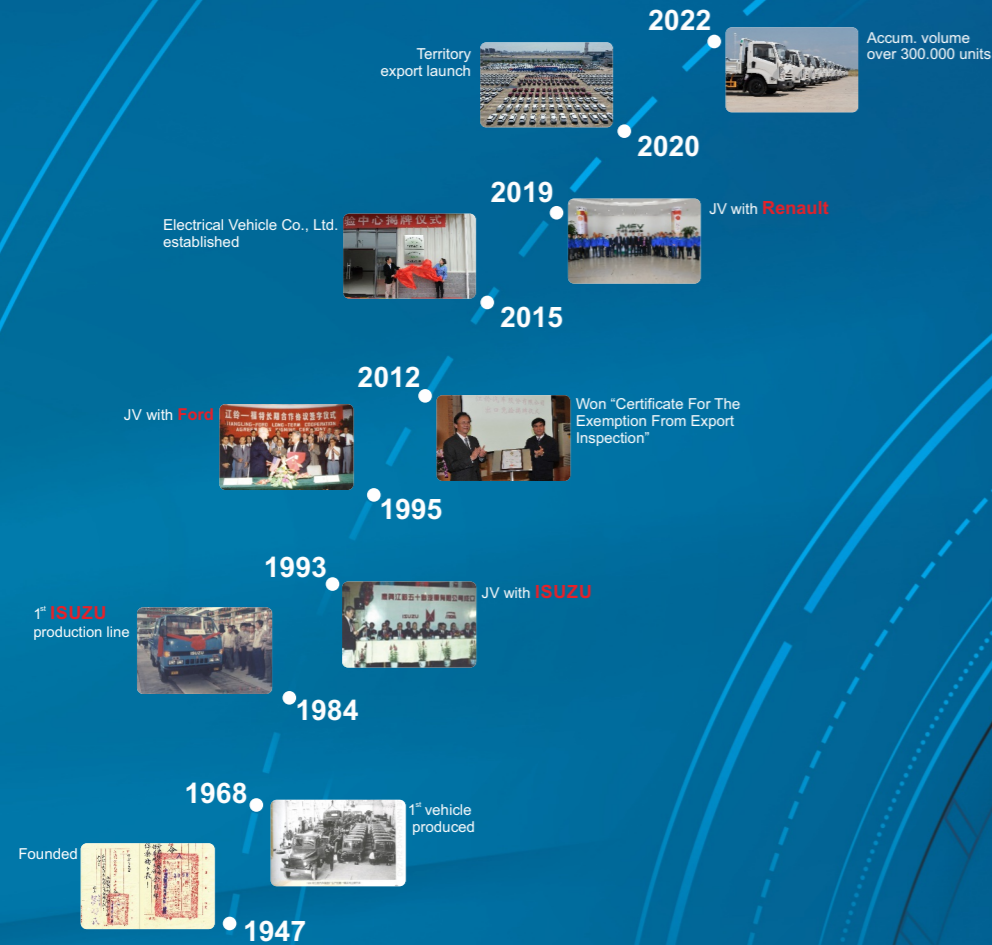

**Jiangxi Jiangling Motors Import & Export Co., Ltd.**  
Add: 969, Jinrong Street, Honggutan District, Nanchang, Jiangxi, China  
Tel: +86-791-86738769 Fax: +86-791-86738577  
Website: www.jmcg-global.com



No.1 Light bus share  
No.1 Ambulance share  
Top 2 Pickup share  
Top 5 Light truck share

# ALL NEW CARRYING PLUS



Jiangling Motors Co., Ltd.

JV with Ford



**JMC**  
f JMCGMotors



# POWERTRAIN



## JX493 2.8L 4-cylinder

Max. power, 90kW  
Max. Torque, 330N-m /1400-2500r/min

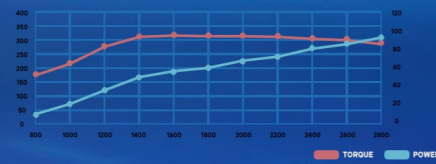

## JX4D30 2.9L 4-cylinder

Max. power 120kW Max. torque 450N-m  
Torque 350Nm at 1000 rpm  
Garrett's 4th generation turbocharger  
HT300 cylinder material with a life expectancy of 700,000 km

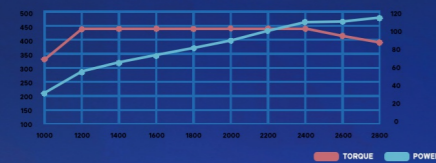

# RIGOROUS TESTING

Leading-edge manufacturing processes to ensure the manufacturing quality of our products JMC-Ford development process.

The agile and robust development process and strict verification standards have established the excellent quality standard of JMC light trucks

**28 ITEMS** Full range of road conditions, including twists, potholes, rocky roads, splash pads and more. Specialised test conditions.

**5000+**  
items Component level verification tests

**400+**  
items Complete vehicle level verification tests

**100+**  
items Complete vehicle road verification, 2 times the industry level.

**3000**  
System level test cases

**3Million**  
kilometres of proven mileage which could circle the earth 70 times

**13%**  
Mountain test mileage exceeds industry standards

**27%**  
bad road test mileage

**1million**  
kilometers complete vehicle durability verification test 10-15% rougher road condition than competitors

**9600+**  
times gear shafting verification test



# INTERIOR

## ERGONOMIC DESIGN

- New driver-centric interior hugging dashboard design  
Flat cabin design with improved the inner space
- 17 storage areas for infinite space extension & USB and 12V power interface
- Reversible handbrake providing a flexible inner space
- Standard with power windows
- Ergonomic seats with 5-level adjustment armrest
- Multifunctional steering wheel



USB for vehicle recorder



Center USB





# LOAD-BEARING

- **STRAIGHT THROUGH BEAM DESIGN:**

Frame section height—180mm

- **FRONT AXLE:**

Made of high-strength alloy steel

For higher strength and load-bearing capacity

- **QSTE650TM FRAME:**

The strongest ultra-high strength steel in the industry

- **MODIFICATION FLEXIBILITY:**

Standard hole design

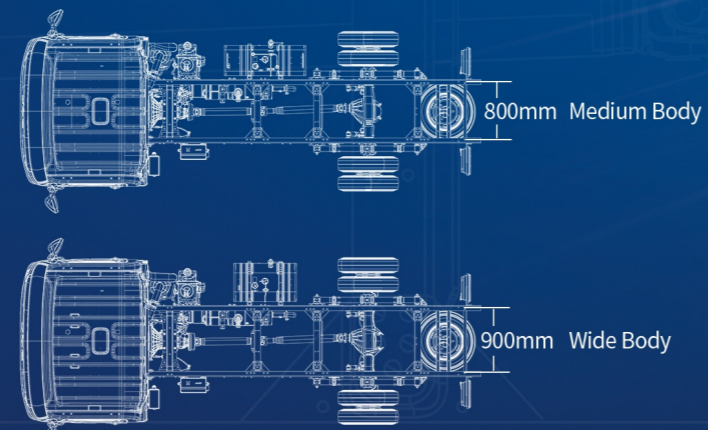
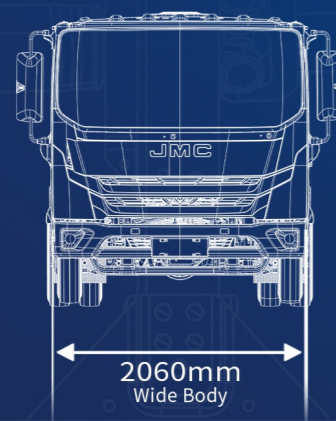
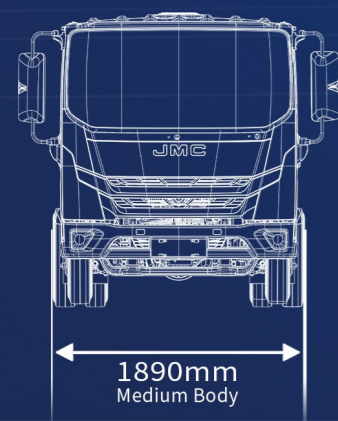

More convenient to install special vehicle modification accessories

## UPGRADE CABIN WIDTH





# ENERGY CONSERVATION

-  0.45 air resistance coefficient
-  0.0065 rolling resistance tires
-  1800 bar high pressure fuel system



# SECURITY



- 1 Hydraulic brake reaches the level of air brake(Air brake optional)
- 2 Wide wheelbase, wide leaf spring distance, Widest 900 mm frame in its class (wide body model)
- 3 4.38° A-pillar obstacle angle for less blind spot, more open view, safer driving



Model	All New Carrying Plus																											
Cabin type	SC/KC/DC				SC/DC				SC/KC				SC															
Emission standard	E2	E4	E5	E6	E2	E4	E5	E6	E2	E4	E5	E6	E4	E5	E6													
<b>Dimension</b>																												
Wheelbase(mm)	2850								3360																			
Cabin width(mm)	1890				1890								2060															
Overall Dimension	SC/KC: 5490*2080*2435/2450				SC: 5990*2080*2425/2435				5990*2180*2445/2465				5990*2180*2445/2465															
Cargo body L*W*H(mm)	DC: 5490*2080*2450/2465				DC: 5990*2080*2435/2450																							
Cargo size L*H(mm)	SC: 3700*440 KC: 3300*440 DC: 2700*440				SC: 4200*440 DC: 3200*440								SC: 4200*440 KC: 3800*440															
<b>Powertrain</b>																												
Engine	JX493																											
Displacement(cc)	2771																											
Max.Output(kw)/Rpm	68/3600				90/3200				68/3600				90/3200		120/2800													
Max.Torque(Nm)/Rpm	220/1800-2200				330/1600-2200				220/1800-2200				330/1600-2200		450/1200-2400													
Gearbox Type	SMT																											
Fuel Tank Capacity (L)	66				105				125				125															
Rear axle speed ratio	6.142				5.571				6.142				5.571		4.222													
<b>Brake&amp;Tire</b>																												
Brake type	Hydraulic				Hydraulic/Air				Hydraulic				Hydraulic/Air		Air													
Tire type	Single Rear Tire/Dual Rear Tires																											
Tire size	Single Rear Tire: 7.0R16 14PR Dual Rear Tires: 7.0R16 10PR				Single Rear Tire: 7.0R16 14PR 205/75 R17.5 Dual Rear Tires: 7.0R16 10PR				7.0R16 10PR				7.0R16 10PR 215/75 R17.5		Standard: 7.0R16 10PR Optional: 7.5R16 16PR		Standard: 7.0R16 10PR 215/75 R17.5 Optional: 7.5R16 16PR											
<b>Weight</b>																												
Kerb weight(kg)	Single Rear Tire: 2265/2280/2400 Dual Rear Tires: 2315/2375/2465		Single Rear Tire: 2305/2325/2440 Dual Rear Tires: 2355/2415/2505		Single Rear Tire: 2340/2355/2475 Dual Rear Tires: 2405/2445/2540		Single Rear Tire: 2345/2360/2480 Dual Rear Tires: 2410/2450/2545		2420/2495		2460/2535		2495/2570		Hydraulic brake: 2500/2575 Air Brake: 2600/2675		2515/2545		Hydraulic brake: 2515/2545 Air Brake: 2615/2645		Hydraulic brake: 2550 Air Brake: 2650		Hydraulic brake: 2555 Air Brake: 2655		2695/2785		2730	2735
GVW(kg)	Single Rear Tire: 4495 Dual Rear Tires: 5495				5495				5495				5495															
<b>Safety</b>																												
ABS	●	●	●	●	●	●	●	●	●	●	●	●	●	●	●													
Exhaust Brake	○	○	○	○	●	●	●	●	●	●	●	●	●	●	●													
Power Steering	●	●	●	●	●	●	●	●	●	●	●	●	●	●	●													
Sound alert for handbrake not released	●	●	●	●	●	●	●	●	●	●	●	●	●	●	●													
Reminder of unfastened seat belt for driver	●	●	●	●	●	●	●	●	●	●	●	●	●	●	●													
LED daytime running light	/	/	/	●	/	/	/	●	/	/	/	●	/	/	●													
<b>Comfort</b>																												
Infotainment System (Bluetooth music / Bluetooth phone / USB music)	●	●	●	●	●	●	●	●	●	●	●	●	●	●	●													
Multifunction steering wheel	●	●	●	●	●	●	●	●	●	●	●	●	●	●	●													
Air conditioning	●	●	●	●	●	●	●	●	●	●	●	●	●	●	●													
Central locking(manual)	●	●	●	●	●	●	●	●	●	●	●	●	●	●	●													
Remote key	●	●	●	●	●	●	●	●	●	●	●	●	●	●	●													
Power windows	●	●	●	●	●	●	●	●	●	●	●	●	●	●	●													
One-touch window lift--driver	●	●	●	●	●	●	●	●	●	●	●	●	●	●	●													
Remote key control glass one-touch lift	●	●	●	●	●	●	●	●	●	●	●	●	●	●	●													
Driver armrest	●	●	●	●	●	●	●	●	●	●	●	●	●	●	●													
Headlight delay off	●	●	●	●	●	●	●	●	●	●	●	●	●	●	●													
Driver overhead storage box	●	●	●	●	●	●	●	●	●	●	●	●	●	●	●													
USB charging port	●	●	●	●	●	●	●	●	●	●	●	●	●	●	●													
Overhead storage box mounted USB port	●	●	●	●	●	●	●	●	●	●	●	●	●	●	●													
12V Socket/ Power Port DC 12V Outlet	●	●	●	●	●	●	●	●	●	●	●	●	●	●	●													
Speed-sensitive automatic door locking	/	●	●	●	●	●	●	●	/	●	●	●	●	●	●													

●:Standard ○:Optional /:Not Available

All information is subject to change.

# JMC World-class supplier



**Light Truck:** Electronic control unit, sensors, oil pump, fuel injector  
**Pick Up/SUV:** Fuel injector, ESP assembly



**SUV (Diesel model):** Intake camshaft



**SUV/Pick Up:** Transfer box assembly, transfer box ECU



**SUV:** Rear oxygen sensor



**Light Van:** ACU (Airbag control unit)



**SUV:** Tyre



**Light Van (Gasoline model):** Clutch, fuel pump plunger  
**SUV (Diesel model):** Generator OAP belt pulley



**SUV/Pick Up:** Electronic gear shifter, automatic transmission, EPS assembly



**Pick Up/ Light Van:** Transmission



**Light Truck:** Exhaust pipe



**SUV:** Tyre



**Light Van:** Seats



**Light Van:** Clutch



**Light Van (Gasoline model):** Battery



**Light Truck/SUV/Pick Up:** Turbocharger



**Light Truck:** Pistons and piston rings



**Light Truck:** Combined instrument, A/C control panels, HVAC, condenser  
**Light Van:** Combined instrument



**SUV/Pick Up:** Exhaust pipe system



Ford Global Quality Improvement Process



Ford Global Product Development System



- Exported to 110 countries and regions  
- UN authorized supplier